

[Previous Screen](#)

Product: MARINE AUXILIARY
Model: 3516B MARINE AUXILIARY S2R
Configuration: 3516B Marine Auxiliary Engine S2R00001-UP

Engine News

2010/01/18**Media Number -SEBD9625-00****Publication Date -18/01/2010****Date Updated -18/01/2010**

i03823136

New O-Ring Seals Are Used on the Front Housings of 3500 Engines {1151, 1162, 1166, 1206, 1207}

SMCS - 1151; 1162; 1166; 1206; 1207

Engine:

- All 3500 Engines

Description of Change: The new O-Ring has an increased sealing capability. This change increases the service life of the seal.

Adaptable To: The new **259-4598** O-Ring Seal is a direct replacement for the **235-3548** O-Ring Seal. The new O-Ring is adaptable back to first production on all 3500 Engines.

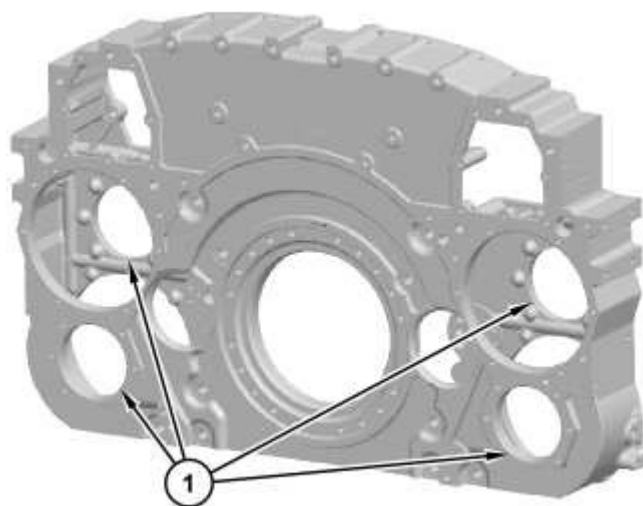

Illustration 1
Front housing

g01953423

(1) **259-4598** O-Ring Seal bores

Note: The bores for the new **259-4598** O-Ring Seal must be lubricated with **207-1601** Rubber Lubricant. Refer to Illustration 1 for the locations of the bores that must be lubricated.

Note: The seals for the idler shaft have not changed. This change is effective for engines with serial numbers that were built after 6 January 2010.

Copyright 1993 - 2010 Caterpillar Inc.
All Rights Reserved.
Private Network For SIS Licensees.

Tue Jan 26 12:16:39 UTC+0100 2010