

GSH9B, GSH15B, GSH20B, GSH22B

Orange Peel Grapples for Hydraulic Excavators



Features

New Design

Wide range of applications

Maintenance

Options available

Benefits

The new design of the orange peel grapples ensures maximum protection of the hydraulics through integration of the hydraulics cylinders into the tines and a guard that protects the hydraulic couplers and lines from damaging, lowering your operating costs.

These grapples can be used for a wide range of applications such as handling shredded scrap, long structural beams, car bodies, and waste at recycling and transfer stations, as well as rocks at construction sites.

Easily accessible lubrication points, hydraulic components are easily accessible behind covering guards. Made of durable wear-resistant materials.

Choice of open, semi-closed and closed shells with a variety of capacities.

CATERPILLAR®

Orange Peel Grapples for Hydraulic Excavators

Specifications and Dimensions

		GSH9B				GSH15B						
		4 Tines		5 Tines		4 Tines				5 Tines		
Type/Capacity	Liter	300	400	300	400	400	500	600	800	400	500	600
Recommended carrier weight												
Excavator class	metric tons	9-15		9-15		15-21				15-21		
Material Handler class	metric tons	9-18		9-18		18-25				18-25		
Operating weight*												
open	kg	530	540	630	640	1155	1160	1175	1210	1375	1380	1395
semi-closed	kg	570	580	670	690	1225	1235	1250	1300	1445	1455	1475
closed	kg	660	690	730	760	1355	1375	1410	1495	1530	1540	1575
narrow	kg	–	–	–	–	–	–	1215	1260	–	–	1450
Maximum lifting capacity	kg	3000		3000		4000				4000		
Hydraulic open/close												
Maximum pressure	bar	350		350		350				350		
Optimum Flow	l/min	80		80		100				100		
Hydraulic rotation												
Maximum pressure	bar	140		140		140				140		
Optimum Flow	l/min	20		20		20				20		
A Height – tines closed	mm	1370	1460	1370	1460	1650	1690	1740	1880	1670	1700	1760
B Height – tines opened	mm	1100	1150	1100	1150	1340	1360	1385	1450	1350	1370	1400
C Diameter – tines closed	mm	1320	1320	1290	1280	1540	1540	1540	1560	1500	1500	1500
D Diameter – tines opened	mm	2000	2150	1940	2090	2260	2325	2415	2640	2190	2250	2340
E Ground clearance – tines opened	mm	540	590	540	580	600	620	640	710	600	620	650
F Pin diameter	mm	50		50		70				70		
G Tine width	mm	85		85		114				114		
H Distance over 2 tines	mm	1500	1610	1280	1370	1700	1740	1810	1970	2085	2145	2230
K Overall width	mm	–	–	1850	1900	–	–	–	–	1440	1440	1440

* Operating weight includes hydraulic rotator and excludes machine link

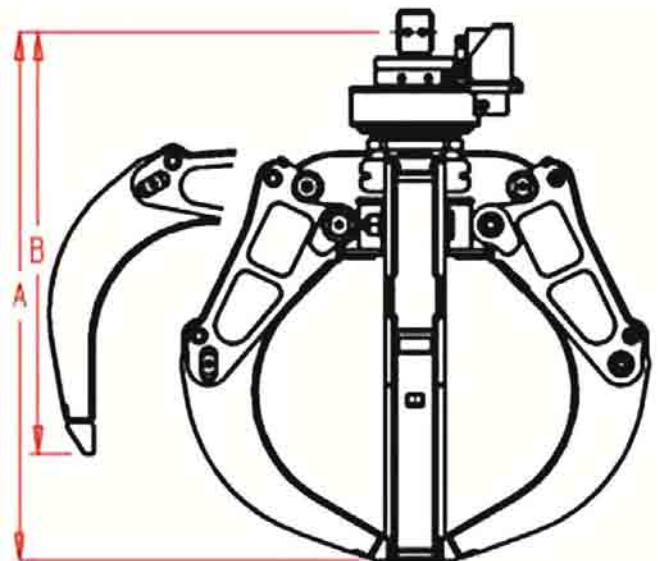

800	GSH20B						GSH22B									
	4 Tines			5 Tines			4 Tines					5 Tines				
	600	800	1000	600	800	1000	600	800	1000	1250	1500	600	800	1000	1250	1500
		20-30		20-30					22-50					22-50		
		25-45		25-45					35-60					35-60		
1465	1545	1570	1605	1820	1855	1900	2255	2295	2315	2350	–	2660	2715	2740	2780	–
1545	1615	1655	1705	1905	1955	2020	2350	2415	2440	2485	–	2770	2855	2890	2945	–
1655	1745	1820	1910	1985	2055	2145	2530	2650	2700	2760	–	2860	2980	3030	3095	–
1515	1575	1615	1660	1870	1920	1975	–	–	2390	–	2410	–	–	2855	–	2880
		8000		8000					12 000					12 000		
		350		350					350					350		
		150		150					200					200		
		200		200					200					200		
		20		20					20					20		
1890	1720	1860	2010	1720	1860	2010	1970	2100	2175	2245	2265	1970	2100	2175	2245	2265
1460	1440	1510	1590	1440	1510	1590	1710	1785	1830	1870	1880	1710	1785	1830	1870	1880
1500	1735	1735	1735	1735	1735	1735	2050	2050	2050	2085	2050	2050	2050	2050	2085	2050
2550	2390	2595	2855	2390	2595	2855	2640	2840	2950	3060	3050	2640	2840	2950	3060	3050
710	640	710	790	640	710	790	770	840	900	915	935	770	840	900	915	935
		80		80					90					90		
		150		150					200					200		
2430	1800	1930	2125	2210	2395	2635	2010	2160	2230	2320	2320	2450	2635	2730	2830	2820
1450	–	–	–	1620	1620	1620	–	–	–	–	–	1915	1915	1915	1950	1815

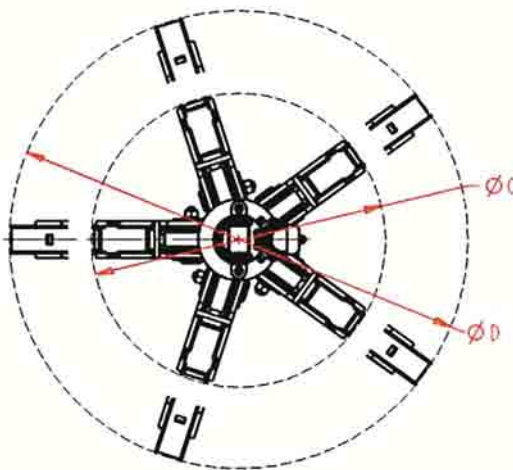
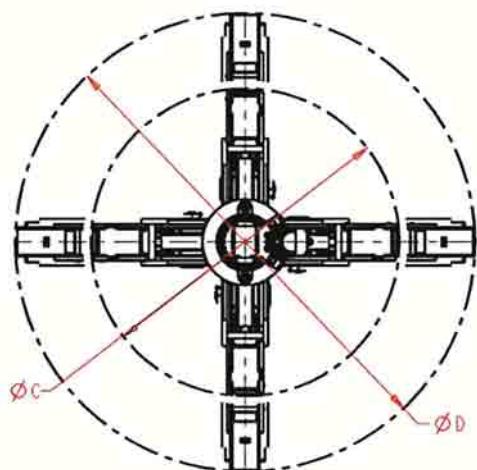

GSH9B, GSH15B, GSH20B, GSH22B Orange Peel Grapples

Hydraulic Requirements

Two way hydraulic high pressure lines for opening/closing and two way hydraulic medium pressure lines for rotation controlled by joystick in the cab or pedal according to customer's choice.

Matching Guide

Orange Peel Grapples	Hydraulic Excavators	Material Handler
GSH9B	312C, 315C, 318C, 319C/319D, 320C/320D, 321C, 323D, M315C, M315D, M316C, M316D, M318C/M318D, M322C/M322D	
GSH15B	312C, 315C, 318C, 319C, 320C/320D, 321C, 323D, M315C, M316C, M318C, M322C	319D MH, 320C MH/320D MH, M318C MH/M318D MH, M322C MH/M322D MH
GSH20B	320C/320D, 321C, 323D, 322C, 324D, 325C, 325D, M318C, M322C/M322D	325C MH/325D MH, 330C MH, M322C MH/M322D MH, M325C MH/M325D MH
GSH22B	322C, 324D, 325C/325D, 330C/330D	330C MH, 345C MH, M325C MH/M325D MH