



Cat[®] 242B Series 3

SKID STEER LOADER

FEATURES:

The Cat[®] 242B Series 3 Skid Steer Loader, with its vertical lift design, delivers extended reach and lift height for quick and easy truck loading. Its stability and lifting performance provides excellent material handling. The 242B Series 3 features the following:

- **Ergonomic operator station** features easy to use pilot operated joystick controls for reduced operator fatigue and increased productivity.
- **High performance power train** provides high engine horsepower and torque, allowing part-throttle operation for lower sound levels and fuel consumption.
- **Advanced hydraulic system** is designed for maximum power and reliability.
- **Easy routine maintenance** helps reduce machine downtime for greater productivity.
- **Broad range of performance matched Cat[®] Work Tools** make the Cat Skid Steer Loader the most versatile machine on the jobsite.

Specifications

Engine

Engine Model	Cat [®] C3.4 DIT	
Gross Power SAE J1995	56 kW	75 hp
Net Power SAE 1349/ISO 9249	53 kW	71 hp
Displacement	3.3 L	201 in ³
Stroke	120 mm	4.7 in
Bore	94 mm	3.7 in

Weights*

Operating Weight	3179 kg	7,008 lb
------------------	---------	----------

Power Train

Travel Speed (Forward or Reverse)		
One Speed	12.4 km/h	7.7 mph
Two Speed Option	18.4 km/h	11.4 mph

Hydraulic System

Hydraulic Flow – Standard:		
Loader Hydraulic Pressure	23 000 kPa	3,335 psi
Loader Hydraulic Flow	83 L/min	22 gal/min
Hydraulic Power (calculated)	31.9 kW	42.8 hp

Operating Specifications*

Rated Operating Capacity	975 kg	2,150 lb
Rated Operating Capacity with Optional Counterweight	1000 kg	2,200 lb
Tipping Load	1950 kg	4,300 lb
Breakout Force, Tilt Cylinder	2204 kg	4,507 lb

Cab

ROPS	SAE J1040 MAY94, ISO 3471:1994
FOPS	SAE J/ISO 3449 APR98 Level I, ISO 3449:1992 Level I
FOPS Level II	SAE J/ISO 3449 APR98 Level II, ISO 3449:1992 Level II (optional)

Service Refill Capacities

Chain Box, each side	6 L	1.6 gal
Cooling System	10 L	2.6 gal
Engine Crankcase	9 L	2.4 gal
Fuel Tank	58 L	15.3 gal
Hydraulic System	55 L	14.5 gal
Hydraulic Tank	35 L	9.2 gal

* Operating Weight, Operating Specifications and Dimensions all based on 75 kg (165 lb) operator, all fluids, 1 speed, OROPS, 1676 mm (66 in) dirt bucket, Cat 12x16.5 tires, no optional counterweights and manual quick coupler (unless otherwise noted).

242B Series 3 Skid Steer Loader

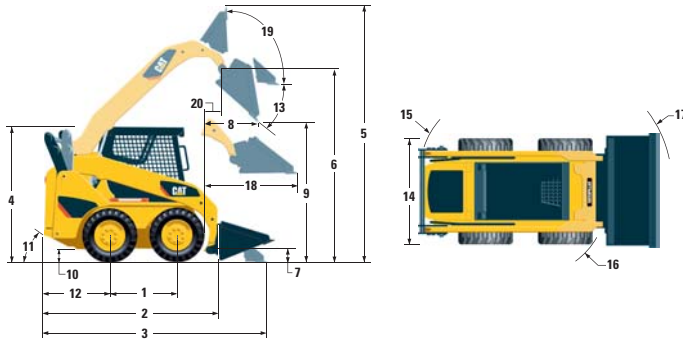

Dimensions*

1 Wheelbase	1094 mm	43.1 in
2 Length w/o Bucket	2760 mm	108.7 in
3 Length w/Bucket on Ground	3437 mm	135.3 in
4 Height to Top of Cab	2019 mm	79 in
5 Maximum Overall Height	3918 mm	154 in
6 Bucket Pin Height at Maximum Lift	3086 mm	121 in
7 Bucket Pin Height at Carry Position	228 mm	9 in
8 Reach at Maximum Lift and Dump	622 mm	24 in
9 Clearance at Maximum Lift and Dump	2333 mm	92 in
10 Ground Clearance	178 mm	7 in
11 Departure Angle	28°	
12 Bumper Overhang Behind Rear Axle	989 mm	39 in
13 Maximum Dump Angle	50°	
14 Vehicle Width over Tires	1676 mm	66 in
15 Turning Radius from Center – Machine Rear	1556 mm	61 in
16 Turning Radius from Center – Coupler	1311 mm	52 in
17 Turning Radius from Center – Bucket	2092 mm	82 in
18 Maximum Reach w/Arms Parallel to Ground	1216 mm	48 in
19 Rack Back Angle at Maximum Height	88°	
20 Bucket Pin Reach at Maximum Lift	254 mm	10 in

MANDATORY EQUIPMENT

- Quick Coupler, Mechanical or Hydraulic
- Seat Belt, 50 mm (2 in) or 75 mm (3 in)
- EU Preparation Package (includes Demand Fan) (Europe only)

COMFORT PACKAGE (must select one of the following)

- Open ROPS (C0): *Static Seat*
- Open ROPS (C1): *Suspension Seat, Deluxe Headliner*
- Enclosed ROPS (C2): *C1 + Heater, Cab Door, Side Windows, Cup Holder, Cab Debris Barrier*
- Enclosed ROPS (C3): *C2 + Air Conditioner*

CONTROL PACKAGE (must select one of the following)

- Control Package 1: *On/Off Auxiliary Hydraulics Basic*
- Control Package 2: *Proportional Auxiliary Hydraulics Deluxe, 1 Speed*
- Control Package 3: *Proportional Auxiliary Hydraulics Deluxe, 1 Speed, Work Tool Harness*
- Control Package 4: *Proportional Auxiliary Hydraulics Deluxe, 2 Speed*
- Control Package 5: *Proportional Auxiliary Hydraulics Deluxe, 2 Speed, Work Tool Harness*

STANDARD EQUIPMENT

ELECTRICAL

- 12 volt Electrical System
- 90 ampere Alternator
- Automatic Glow Plug Activation
- Heavy Duty Battery, 880 CCA
- Ignition Key Start/Stop Switch
- Lights: *Gauge Backlighting, Two Rear Tail Lights, Two Adjustable Front and Rear Halogen Lights, Dome Light*

OPERATOR ENVIRONMENT

- Gauges: *Fuel Level, Hour Meter*
- Operator Warning System Indicators: *Air Filter Restriction, Alternator Output, Armrest Raised/Operator Out of Seat, Engine Coolant Temperature, Engine Oil Pressure, Glow Plug Activation, Hydraulic Filter Restriction, Hydraulic Oil Temperature, Parking Brake Engaged*
- Vinyl Seat
- Pull Down Ergonomic Contoured Armrest
- Control Interlock System, when operator leaves seat or armrest raised: *Hydraulic System Disables, Hydrostatic Transmission Disables, Parking Brake Engages*
- ROPS Cab, Open, Tilt Up
- FOPS, Level I
- Top and Rear Windows
- Floor Mat
- Interior Rear View Mirror
- 12 volt Electric Socket
- Horn
- Backup Alarm

POWER TRAIN

- Cat® C3.4 DIT Tier 4 Interim/Stage IIIA Compliant Diesel Engine
- Air Cleaner, Dual Element, Radial Seal
- S-O-SSM Sampling Valve, Hydraulic Oil
- Filters: Spin on, Hydraulic
- Filters: Bayonet-type, Fuel and Water Separator
- Tilt Up Radiator/Hydraulic Oil Cooler
- Muffler, Standard
- Spring Applied, Hydraulically Released Parking Brakes
- Hydrostatic Transmission
- Four Wheel Chain Drive

OTHER

- Engine Enclosure, Lockable
- Extended Life Antifreeze, -36° C (-33° F)
- Machine Tie Down Points (4)
- Support, Lift Arm
- Hydraulic Oil Level Sight Gauge
- Radiator Coolant Level Sight Gauge
- Radiator, Expansion Bottle
- Cat® ToughGuard™ Hose
- Auxiliary, Hydraulics, Continuous Flow
- Heavy Duty, Flat Faced Quick Disconnects
- Split D-Ring to Route Work Tool Hoses Along Side of Left Lift Arm
- Electrical Outlet, Beacon
- Belly Pan Cleanout

OPTIONAL ATTACHMENTS

- Counterweight, increases rated operating capacity 23 kg (50 lb)
- Variable Speed Demand Fan
- Beacon, Rotating
- Engine Block Heater – 120V or 240V
- Oil, Hydraulic, Cold Operation
- Paint, Custom

For more complete information on Cat products, dealer services, and industry solutions, visit us on the web at www.cat.com

AEHQ6124 (05-10)

© 2010 Caterpillar
All Rights Reserved
Printed in U.S.A.

Materials and specifications are subject to change without notice. Featured machines in photos may include additional equipment. See your Caterpillar dealer for available options.

CAT, CATERPILLAR, SAFETY.CAT.COM, their respective logos, "Caterpillar Yellow" and the "Power Edge" trade dress, as well as corporate and product identity used herein, are trademarks of Caterpillar and may not be used without permission.

CATERPILLAR®