

D9T

Track-Type Tractor



Engine

Engine Model	Cat® C18 ACERT™	
Flywheel Power	306 kW	410 hp
Gross Power	346 kW	464 hp

Weights

Operating Weight	47 900 kg	105,600 lb
Shipping Weight	37 104 kg	81,800 lb

- **Operating Weight:** Includes hydraulic controls, blade tilt cylinder, coolant, lubricants, 100% fuel, ROPS, FOPS cab, SU-Blade, Single-Shank Ripper, 610 mm (24 in) ES shoes, and operator.
- **Shipping Weight:** Includes coolant, lubricants, 20% fuel, ROPS, FOPS cab, and 610 mm (24 in) ES shoes.

D9T Track-Type Tractor

Strength from the past. Power for the future.™ The D9T combines power and efficiency with advanced technology for outstanding production at a lower cost-per-yard.

C18 Engine with ACERT® Technology

- ✓ ACERT Technology works at the point of combustion to optimize engine performance and provide low exhaust emissions. Matched with the torque converter and power shift transmission, it provides years of dependable and efficient service. **pg. 4**

Operator Station

- ✓ Designed for operator comfort, convenience, and productivity. Machine control and vital information is provided at the operator's fingertips. A full day of work is no problem in this efficient work place. **pg. 6**

Implement and Steering Controls

- ✓ Electro-hydraulic implement controls allow low operator effort for dozing and ripping. Steering and gear selection in a one-hand control system enhances operator comfort. **pg. 8**

Work Tools

Various bulldozer blades, rippers, winches, and other options allow you to adapt the D9T to match your specific application, making you more productive. **pg. 12**

Serviceability and Customer Support

- ✓ Combining easy to access, modular components with your Caterpillar® Dealer's advanced rebuild and repair capabilities ensures rapid component replacement and minimum downtime. **pg. 13**

Engineered for demanding work.

The durable construction of the D9T is well suited for tough working conditions. Combined with the C18 engine for superior performance, fuel economy and meeting emission targets with the help of ACERT Technology, it keeps material moving with the reliability and low operating costs you expect from Cat® tractors.



Drive Train

The electronically controlled power shift transmission, efficient differential steering and durable planetary final drives deliver outstanding power transfer and long life to ensure maximum productivity. **pg. 9**

Undercarriage

The proven elevated sprocket undercarriage isolates the drive train components from ground-induced impacts. The suspended undercarriage puts more track on the ground for higher traction and less track slip. It absorbs shocks for a smoother ride and longer machine life. **pg. 10**

Structure

Mainframe is heavy, strong and durable. Full box sections, steel castings and continuous rolled rails provide durable support to the suspended undercarriage, elevated final drives and other integral frame components. **pg. 11**



✓ *New Feature*

C18 Engine with ACERT® Technology

A combination of innovations working at the point of combustion, ACERT Technology optimizes engine performance while meeting EPA Tier 3 and EU Stage IIIa engine exhaust emission regulations for off-road applications.



C18 Engine. Performing at full-rated net power of 306 kW (410 hp) at 1,800 rpm, the large displacement and high torque rise allow the D9T to doze through tough material. Matched to the high efficiency torque converter and electronically controlled power shift transmission, it will provide years of dependable service.

C18 Block. The one-piece, grey iron block features generous ribbing for stiffness and heavy bearing bulkheads for rigidity and strength. Incorporation of straight o-ring connection points reduces the loss of engine oil and fluids.

Overhead Cam. Gears drive an overhead cam on the front end of the engine. To reduce wear, a pendulum absorber is mounted at the front of the camshaft. These features contribute to the long-life and durability of this engine.



ADEM™ A4 Engine Controller.

The ADEM A4 electronic control module manages fuel delivery to get the best performance per gallon (liter) of fuel used. It provides flexible fuel mapping, allowing the engine to respond quickly to varying application needs. It tracks engine and machine conditions while keeping the engine operating at peak efficiency.

Fuel Delivery. Multiple injection fuel delivery involves a high degree of precision. Precisely shaping the combustion cycle lowers combustion chamber temperatures, generating fewer emissions and optimizing fuel combustion; translating into more work output for your fuel cost.

More Complete Fuel Combustion.

High cylinder pressures combined with tightly controlled tolerances promote extremely efficient fuel burn, less blow by, and lower emissions.

MEUI Fuel System. A highly evolved fuel system with a proven record of reliability in the field. MEUI combines the technical advancement of an electronic control system with the simplicity of direct mechanically controlled unit fuel injection. The MEUI system excels in its ability to control injection pressure over the entire engine operating speed range. These features allow the C18 to have complete control over injection timing, duration, and pressure.

ATAAC and Airflow. Air-to-air aftercooling keeps air intake temperatures down and, in concert with the tight tolerance combustion chamber components, maximizes fuel efficiency and minimizes emissions. Significant improvements in air flow are generated by a water-cooled turbocharger, unique cross-flow head and a single overhead cam.

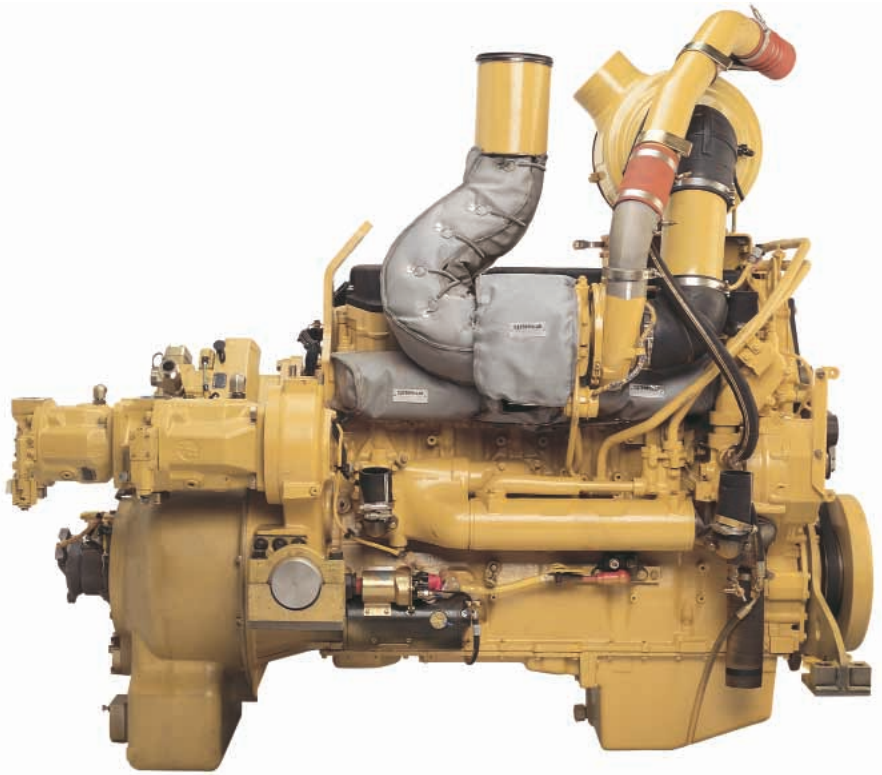

Service. Easier maintenance and repair through monitoring key functions and logging critical indicators. Electronic diagnostic access is possible with a single tool, the Cat Electronic Technician.

Turbocharging and Air-to-Air Aftercooling. Provides high horsepower with faster response time while keeping intake temperatures low for long hours of continuous operation.

Operator Station

Designed for operator comfort, convenience, and productivity, the state-of-the-art cab sets a new standard.



1) Steering Control. Dual-twist tiller control with standard differential steering controls direction and degree of turns, forward-reverse shifting, and gear selection in a single control handle – enhancing operator comfort.

2) Cat Comfort Series Seat.

Fully adjustable and designed for comfort and support. Thick seat and back cushions provide support for the lower back and thighs, while allowing unrestricted arm and leg movement. Wide retractable seat belt provides positive and comfortable restraints.

3) Adjustable Armrests. Standard adjustable armrests provide additional comfort for the operator.



4) Electronic Ripper Control. A rigidly mounted handgrip, with low effort thumb and finger controls, provides firm support and positive control of the ripper when operating in tough conditions. Programmable features, such as Auto Lift, Shank-Out and Auto Stow, increase efficiency for the operator.

5) Electronic, Programmable Dozer Control. Features such as blade response, blade float and auto blade can be set and adjusted using the Advisor panel. Auto Blade Assist option makes the tractor even more efficient in specific applications.

6) Cat Monitoring Display System.

The combination dash mounted instrument cluster and the Advisor Monitoring System provide key machine operating information and give the operator and service technician insight into the machine's operation and maintenance needs.

In-Dash Instrument Cluster.

The instrument panel, with easy to read gauges and warning lamps, keeps the operator aware of any potential problems. All gauges and readouts are easily visible in direct sunlight.

Advisor Monitoring System (AMS).

On-board diagnostic abilities minimize downtime and maximize machine performance.

7) Wide Panoramic View. The operator station offers an exceptional viewing area. A large view hole in the single-shank ripper frame provides a view of the ripper tip. The tapered hood, notched fuel tank and narrow single-shank ripper carriage give the operator a clear line of sight to the front and rear work areas. The large single-pane door windows provide an excellent view to the sides and blade.

8) Heating and Air Conditioning.

Conveniently located air circulation vents evenly distribute airflow within the cab. Controls are easily accessible from the operator seat.



Fuse Panel and Diagnostic Access.

The new compartment features a single location fuse panel that includes a diagnostic port for the Cat ET to connect for rapid machine diagnostics.

Comfortable Operation. Standard isolation-mounted cab reduces noise and vibration. The cab is pre-wired for a 12-volt or 24-volt entertainment radio, equipped with two speakers, an antenna and a radio mount recessed in the headliner which is also pre-wired for a 12-volt communications radio.

Footpads. Two footpads, mounted on the floor and wide, sweeping stabilizer pad keep the operator comfortable and in control while working on slopes.

Other Features.

- Built-in storage space with tie downs for lunch box or other personal items, plus a glove box and coat hook.
- Ashtray and cup holder.
- Inside door releases.
- Power point plug-in on the right hand console (12-volt laptop and wireless phone compatible) and a similar power point in the fuse panel.

Implement and Steering Controls

Low effort control functions significantly reduce operator fatigue for increased performance.



Dozer Control Lever. A low-effort electronic dozer control handle gives the operator control of all dozer functions with one hand. Fore/aft movement of the lever lowers and raises the blade. Left/right movement directionally tilts the blade.

When equipped with the optional Dual Tilt feature, the thumb lever at the top of the handle controls blade pitch fore and aft. The trigger switch toggles between single and dual tilt.

The left and right side thumb buttons provide control over the semi-automated blade pitch functions that the Dual Tilt attachment provides. Blade pitch for load, carry and spread segments can be preset on Advisor and controlled by the buttons. The left side button cycles between the pitch settings for each segment of the push cycle. The right side button cancels out of the pitch functions without losing the preset pitch angles. This Auto Blade Assist (ABA) feature is turned on and off using a switch on the right side console.

The two buttons also provide control over the AccuGrade™ blade control attachment when the machine is so equipped. The buttons turn on AccuGrade, provide manual increment and decrement control, and turn off AccuGrade.

AccuGrade® Ready Option (ARO).

The AccuGrade Ready Option (ARO) provides a factory installed on-board platform for the AccuGrade GPS installation. All of the changes required to the electrical system, hydraulic system, blade, and cab are incorporated into the ARO. Mounting brackets added on the blade allow easy installation of the masts. Console mounting in the cab secure the in-cab display. Plug-in points inside the cab and on the front of the machine make it easy to install electronic components.

AccuGrade GPS Control System.

The AccuGrade Global Positioning System (GPS) is the best solution when the construction site involves contours, rather than single or dual slope planes. A GPS system compares the blade position to a three-dimensional computerized job site plan and signals the operator or hydraulic system to raise or lower the blade to achieve the design requirements.

Computer Aided Earthmoving System (CAES) (optional).

This on-board electronic site plan directs machine operators, in real-time, where to cut and fill. A graphical map of the design plan and a view of the machine's horizontal and vertical position simplify operation and enhance production. This advanced information tool combines GPS technology (centimeter-level) and in-cab computing capabilities for precise grade and slope control. It has proven to provide measurable impact on work quality and overall productivity.



Ripper Control Lever. A rigidly mounted handgrip provides firm support for the operator even when ripping in the roughest terrain. The low effort thumb lever controls raising and lowering. The finger lever controls shank-in and shank-out positioning. The thumb button automatically raises the ripper.



Tiller Control System. A single lever, dual-control tiller controls machine speed, direction, and steering. The tiller allows the operator to work precisely in close areas, around structures, grade stakes, other machines and during fine grading.

Drive Train

The drive train provides maximum efficiency in combination with the C18 engine with ACERT Technology.



Torque Converter. A high efficiency torque converter with fixed stator provides high torque multiplication while shielding the drive train from sudden torque shocks and vibration.

Additional Feedback. A minor, but important, by-product of the torque converter is its tendency to increase engine lug all the way to converter stall. This gives the operator additional feedback concerning tractor speed and drawbar pull.

Differential Steering System. A planetary differential turns the machine by speeding up one track and slowing the other, while maintaining full power to both. Differential steering system consists of:

- Three planetary gear sets:
- Two planetary gear sets (steering and drive) make up the “dual differential,” which performs the traditional drive function (forward or reverse). Unlike competitive machines, the differential also performs a steering function with input from the steering motor.
- A third planetary gear set, the “equalizing planetary,” resides inside the transmission case. It is connected to the dual differential, which provides a maximum speed difference between the right and left final drives during a turn.

- A dedicated variable-displacement hydraulic pump.
- A bi-directional, fixed-displacement steering motor.
- Heavy-duty steering drive gears.

Operation. When moving straight ahead, power flows through the transmission pinion and bevel gear into the dual differential, transmitting equal, uninterrupted power to each final drive. While turning, power is shifted to the outboard track speeding it up. The inboard track slows down to accommodate a tighter turning radius. Forward ground speed remains the same throughout the turn.

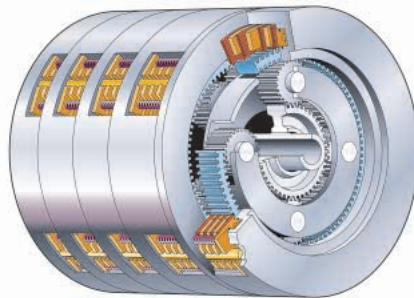

Planetary Power Shift Transmission.

Three speeds forward and three speeds reverse, utilizing large diameter, high capacity, oil-cooled clutches.

- Modulation system permits fast speed and direction changes.
- Modular transmission and differential slide into rear case for servicing ease, even with ripper installed.
- Oil-to-water cooler for maximum cooling capacity.
- Forced oil flow lubricates and cools clutch packs to provide maximum clutch life.

Power Shift with Differential Steer

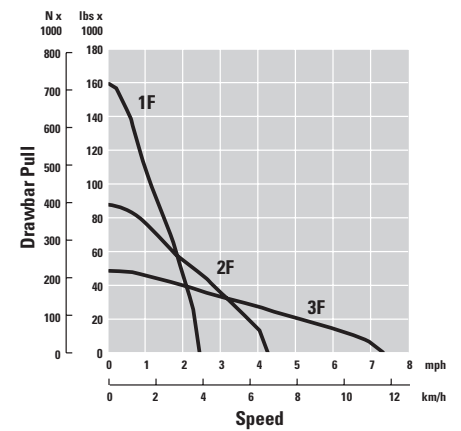

Drawbar Pull vs. Speed. As loads on the tractor increase, the D9T offers unmatched lugging capability and smooth shifting as the need occurs to change gears under varying loads. The 3-speed forward, 3-speed reverse transmission, backed by differential steering, offers excellent runout speeds and accurate steering capability under load.



Elevated Final Drives. Isolated from ground and equipment induced impact loads for extended power train life.

- Crown-shaved drive gears provide smooth, quiet, low maintenance operation.
- Splash lubrication and Duo-Cone® Seals extend service life.

Undercarriage

The Caterpillar elevated sprocket undercarriage is designed for optimized machine balance and best possible performance and component life.



Suspended Undercarriage Design.

Suspended undercarriage design absorbs impact loads, to reduce the shock loads transferred to the undercarriage, by up to 50 percent in uneven terrain.

Bogie Suspension. Bogie suspension conforms closely to the ground providing up to 15 percent more ground contact, especially in hard, uneven terrain. Higher traction means less slippage, better balance, and a smoother ride.



Integrated Carrier Roller Mount.

The carrier roller mount is cast into the track roller frame making it easier to add the optional carrier roller in the field, if conditions require it.

Rollers and Idlers. Feature symmetric Duo-Cone seals for long sealing life to prevent oil loss and dirt entry. Toric rings maintain performance over a wide range of temperatures. Rollers and idlers are serviceable and rebuildable to provide value. Abutment-style caps securely attach rollers and idlers to the bogies.

Roller Frames. Roller frames are tubular to resist bending and twisting, with added reinforcement where operating loads are highest.

- Roller frames attach to tractor by a pivot shaft and pinned equalizer bar.
- Large pivot shaft bushings operate in an oil reservoir.
- A low friction, no maintenance bushing is used in the saddle connection.
- Aligned to use more of the available wear material, running the track to the outside of the rollers in forward and to the inside in reverse.

Sprocket Segments. Made exclusively of Caterpillar Tough Steel™ for longer wear life and precision machined after heat treat for proper fit. Segments can be removed or replaced without breaking the track.

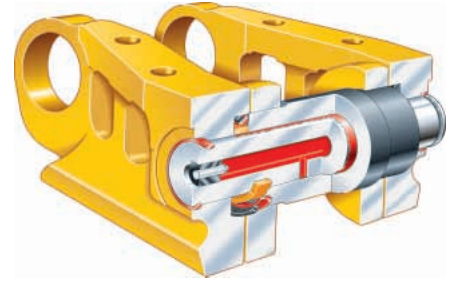

Positive Pin Retention (PPR) Sealed and Lubricated Track. Designed for high-impact and high load applications. The PPR exclusive Caterpillar design locks the link to the pin.

Track Shoes. Track shoes available in a variety of sizes and styles to best match the working conditions.

ARM Shoes. Abrasion Resistant Material (ARM) shoes are available for hard rock applications, significantly reducing unbalanced track shoe wear and improving grouser life.

Structure

Engineered to provide durability and the solid support necessary for maximum production and service life in the most demanding work.



Mainframe Strength. The D9T mainframe is built to absorb high impact shock loads and twisting forces.

Frame Rails. Full box section, designed to keep components rigidly aligned.

Heavy Steel Castings. Adds strength to the main case, equalizer bar saddle, front cross member and tag-link trunnion.

Top and Bottom Rails. Continuous rolled sections, with no machining or welding, to provide superior mainframe durability.

Main Case. Elevates the final drives well above the ground level work area to protect them from impact loads, abrasion and contaminants.

Pivot Shaft. The D9T pivot shaft runs through the mainframe and connects to the roller frames, allowing independent oscillation. The full-length pivot shaft distributes impact loads throughout the case, reducing the bending stress on the case.

Equalizer Bar. The equalizer bar features limited slip seals and an oil-lubricated joint for better oil flow. Large forged pads reduce wear on the mainframe and extend sealed joint life.



Tag-Link. The Tag-Link brings the blade closer to the machine for more precise dozing and load control.

The Tag-Link design provides solid lateral stability and better cylinder positions for constant break out force, independent of blade height.

Work Tools

Work Tools and Ground Engaging Tools (G.E.T.) provide the flexibility to match the machine to the job, maximizing performance.



Bulldozers. All blades feature a strong box-section design that resists twisting and cracking. Blades are made of Cat DH-2™ steel that has high tensile strength and stands up to the most severe applications. Heavy moldboard construction and hardened bolt-on cutting edges and end bits add strength and durability.

- **High-Capacity Universal Blade.**

The high-capacity Universal blade offers maximum capacity and is perfect for moving big loads over long distances. The “U” blade has large blade wings and is ideal for stockpile work, reclamation, charging hoppers or trapping for loaders.

- **Semi-Universal Blade.** The Semi-Universal blade is built for tough applications where penetration is more important than capacity. The “SU” blade is more aggressive in penetrating and loading material than the “U” blade. The blade wings are designed for superior load retention and penetration in tightly packed materials and for finishing applications. Can also be configured with a push plate for push loading scrapers.

- **Abrasion Versions.** The abrasion versions of the “SU” blade and “U” blade are available to extend blade life in more severe applications. Abrasion blades are equipped with rock guards, wear plates and extended wear-life cutting edges and end bits.

Optional Dual Tilt. Improves load control and allows the operator to optimize the blade pitch angle for each portion of the dozing cycle.

Single Lever. Controls all blade movements, including the optional dual tilt.

Cutting Edges and End Bits. Cutting edges are DH-2 steel. End bits are DH-3™ steel to provide maximum service life in tough materials.

Rippers. Single and multi-shank rippers are made to penetrate tough material fast and rip thoroughly for use in a variety of materials.



Single-Shank Ripper. Operator can adjust the shank depth from the seat using an optional single-shank pin puller. Large upper frame view hole improves ripper tip visibility. Heat-treated spacer bars in the ripper carriage extend pocket life and reduce shank notching. Large one-piece shank is available in deep ripping configuration.



Multi-Shank Ripper. Tailors the tractor to the material by using one, two or three shanks.

Hydraulic Pitch Adjustment Cylinders.

Hydraulic pitch adjustment cylinders vary the shank angle to get the best penetration so the material is lifted and shattered.

Hydraulics. The D9T features field-proven load-sensing hydraulics which respond to operating requirements by automatically and continually adjusting attachment hydraulic power, increasing both operator and machine efficiency.

Precise Power for Dozing or Ripping.

During normal blade or ripper corrections, pump output increases and decreases to provide precise power for dozing or ripping.

More Drawbar Power. Lower pump requirements reduce engine power requirements for the hydraulics, making more drawbar power available for increased machine production

Variable-Flow Design. The D9T variable-flow design minimizes hydraulic oil temperatures and saves on fuel.

Implement Valve. The standard D9T implement valve incorporates the components necessary to install a ripper. This makes it “ripper ready,” improving versatility and resale value.

Rear Counterweights. Provide proper tractor balance to maximize dozing production. Recommended if not equipped with any other rear attachment.

Winches. Several options are available. Contact your Caterpillar Dealer.

Serviceability and Customer Support

The most serviceable machines from the most committed dealers. World-class product support. The Cat Dealer network trained experts keep your fleet up and running, maximizing your equipment investments. Caterpillar. The difference counts.™

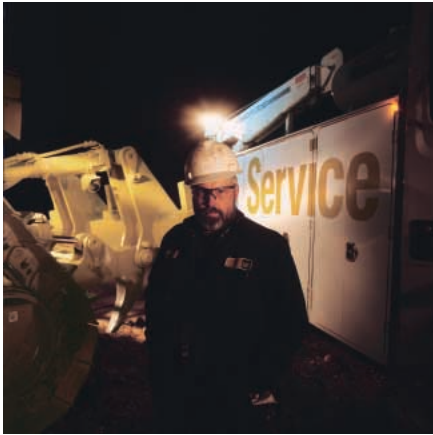

Serviceability. Minimizes maintenance and repair downtime. New sight gauges, filter locations, improved access to oil and coolant sampling ports, and an engine compartment mounted work lamp, make daily and periodic service faster and easier. Equipped with a dozer and ripper, there are only 16 lube points.

Built-in Servicing Ease. Less service time means more working time. Major components are made as modules and most can be removed without disturbing or removing others.

Service Intervals. The time between fluid and filter service intervals minimizes downtime and maximizes productivity.

Engine Oil Filter. Engine oil filter is located on the engine for easy servicing access and minimal downtime. Further time is saved with the optional fast fuel and quick oil change attachments.

Water Separator and Fuel Filter. Easily located in compartment on front of fuel tank, on top of the fender, the water separator functions as the primary fuel filter, just ahead of the secondary fuel filter.

Quick Disconnect Fittings. Allow for fast diagnosis of the power train, hydraulics and attachment oil systems.

S•O•SSM Analysis. Scheduled Oil Sampling made easier through live sampling ports for the engine oil, hydraulics and coolant.

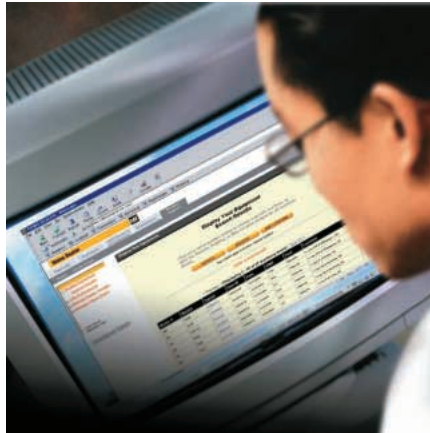

Caterpillar Product Link PL321 SR (optional). This option allows the customer or dealer to obtain machine diagnostics and location information from their offices. Product Link PL321 SR provides updates on service meter hours, machine condition and machine location, as well as integrated mapping/route planning. Built-in flexibility allows for future technology development.

Machine Selection. Make detailed comparisons of the machines you are considering before you buy. How long do components last? What is the cost of preventive maintenance? What is the true cost of lost production? Your Cat Dealer can give you answers to these very important questions.

Purchase. Consider the financing options available, as well as day-to-day operating costs. This is also the time to look at dealer services that can be included in the cost of the machine to yield lower equipment owning and operating costs over the long run.

Product Support. Plan for effective maintenance before buying equipment. Choose from your dealer's wide range of maintenance services at the time you purchase your machine. Programs such as Custom Track Service (CTS), S•O•S analysis, Technical Analysis and guaranteed maintenance contracts give peak life and performance to your machine.



Parts Program. You will find nearly all parts at your dealer parts counter. Cat Dealers use a worldwide computer network to find in-stock parts to minimize machine downtime.

Ask about your Cat Dealer's exchange program for major components. This can shorten repair time and lower costs.

Remanufactured Components. Genuine Cat Remanufactured parts save you money. You receive the same warranty and reliability as new products at cost savings of 40 to 70 percent. Components available for drive train, engine, and hydraulics.

Operation. Improving operating techniques can boost your profits. Your Cat Dealer has training videotapes, literature, and other ideas to help you increase productivity.

Replacement. Repair, rebuild or replace? Your Cat Dealer can help you evaluate the costs involved so you can make the right choice.

Engine

Engine Model	Cat® C18 ACERT™	
Flywheel Power	306 kW	410 hp
Gross Power	346 kW	464 hp
Net Power – Caterpillar	306 kW	410 hp
Net Power – ISO 9249	306 kW	410 hp
Net Power – SAE J1349	302 kW	405 hp
Net Power – EU 80/1269	306 kW	410 hp
Net Power – DIN 70020	428 PS	
Bore	145 mm	5.7 in
Stroke	183 mm	7.2 in
Displacement	18.1 L	1,106 in ³

- Engine ratings apply at 1,800 rpm.
- Net power advertised is the power available at the flywheel when the engine is equipped with fan at max speed, air cleaner, muffler and alternator.
- No derating required up to 2286 m (7,500 ft) altitude, beyond 2286 m (7500 ft) auto derating occurs at 3% per 1,000 ft.

Service Refill Capacities

Fuel Tank	889 L	235 gal
Cooling System	104 L	27.5 gal
Engine Crankcase*	38 L	10 gal
Power Train	164 L	43.4 gal
Final Drives (each)	15 L	3.9 gal
Roller Frames (each)	45 L	11.7 gal
Pivot Shaft Compartment	30 L	7.8 gal
Hydraulic Tank	89 L	23.5 gal

* With oil filters.

Weights

Operating Weight	47 900 kg	105,600 lb
Shipping Weight	37 104 kg	81,800 lb

- Operating Weight: Includes hydraulic controls, blade tilt cylinder, coolant, lubricants, 100% fuel, ROPS, FOPS cab, SU-Blade, Single-Shank Ripper, 610 mm (24 in) ES shoes, and operator.
- Shipping Weight: Includes coolant, lubricants, 20% fuel, ROPS, FOPS cab, and 610 mm (24 in) ES shoes.

Undercarriage

Shoe Type	Extreme Service	
Width of Shoe	610 mm	24 in
Shoes/Side	43	
Grouser Height	84 mm	3.3 in
Pitch	240 mm	9.44 in
Ground Clearance	596 mm	23.5 in
Track Gauge	2250 mm	89 in
Length of Track on Ground	3474 mm	11 ft 5 in
Ground Contact Area	4.24 m ²	6,569 in ²
Track Rollers/Side	8	
Number of Carrier Rollers	1 per side (optional)	
Standard – Ground Pressure	110.9 kPa	16.08 psi

- Positive Pin Retention Track.

Hydraulic Controls

Pump Type	Piston-type pump geared from flywheel	
Pump Output (Steering)	383 L/min	101 gal/min
Pump Output (Implement)	226 L/min	60 gal/min
Tilt Cylinder Rod End Flow	137 L/min	36 gal/min
Tilt Cylinder Head End Flow	167 L/min	44 gal/min
Bulldozer Relief Valve Setting	26 200 kPa	3,800 psi
Tilt Cylinder Relief Valve Setting	19 300 kPa	2,800 psi
Ripper (Lift) Relief Valve Setting	26 200 kPa	3,800 psi
Ripper (Pitch) Relief Valve Setting	26 200 kPa	3,800 psi
Steering	40 500 kPa	5,875 psi
Tank Capacity	89 L	23.5 gal

- Steering Pump output measured at 2239 rpm and 30 000 kPa (4,351 psi).
- Implement Pump output measured at 1800 rpm and 20 000 kPa (2900 psi).
- Electro-hydraulic pilot valve assists operations of ripper and dozer controls. Standard hydraulic systems includes four valves.
- Complete system consists of pump, tank with filter, oil cooler, valves, lines, linkage and control levers.

Transmission

1 Forward	3.9 km/h	2.4 mph
2 Forward	6.8 km/h	4.2 mph
3 Forward	11.7 km/h	7.3 mph
1 Reverse	4.7 km/h	2.9 mph
2 Reverse	8.4 km/h	5.2 mph
3 Reverse	14.3 km/h	8.9 mph
1 Forward – Drawbar Pull (1000)	716.5 N	161 lbf
2 Forward – Drawbar Pull (1000)	400.5 N	90 lbf
3 Forward – Drawbar Pull (1000)	222.5 N	50 lbf

Blades

Type	9SU	
Capacity (SAE J1265)	13.5 m ³	17.7 yd ³
Width (over end bits)	4310 mm	14 ft 3 in
Height	1934 mm	6 ft 5 in
Digging Depth	606 mm	23.9 in
Ground Clearance	1422 mm	56 in
Maximum Tilt	940 mm	37 in
Weight* (without hydraulic controls)	6543 kg	14,425 lb
Total Operating Weight** (with Blade and Single-Shank Ripper)	47 900 kg	105,600 lb
Type	9U	
Capacity (SAE J1265)	16.4 m ³	21.4 yd ³
Width (over end bits)	4650 mm	15 ft 3 in
Height	1934 mm	6 ft 5 in
Digging Depth	606 mm	23.9 in
Ground Clearance	1422 mm	56 in
Maximum Tilt	1014 mm	39.9 in
Weight* (without hydraulic controls)	7134 kg	15,727 lb
Total Operating Weight** (with Blade and Single-Shank Ripper)	48 491 kg	106,902 lb

* Includes blade tilt cylinder.

**Total Operating Weight: Includes hydraulic controls, blade tilt cylinder, coolant, lubricants, 100% fuel, ROPS, FOPS cab, Blade, Single-Shank Ripper, 610 mm (24 in) ES shoes, and operator.

Rippers

Type	Single-Shank, Adjustable Parallelogram	
Number of Pockets	1	
Maximum Clearance Raised (under tip, pinned in bottom hole)	882 mm	34.7 in
Maximum Penetration (standard tip)	1231 mm	48.46 in
Maximum Penetration Force (shank vertical)	153.8 kN	34,581 lb
Pry out Force	320.5 kN	72,025 lb
Weight (without hydraulic controls)	4854 kg	10,700 lb
Total Operating Weight* (with SU-Blade and Ripper)	47 900 kg	105,600 lb
Type	Multi-Shank, Adjustable Parallelogram	
Number of Pockets	3	
Overall Beam Width	2640 mm	103.9 in
Maximum Clearance Raised (under tip, pinned in bottom hole)	885 mm	34.8 in
Maximum Penetration (standard tip)	798 mm	31.42 in
Maximum Penetration Force (shank vertical)	147.9 kN	33,249 lb
Pry out Force (Multi-Shank Ripper with one tooth)	332 kN	74,639 lb
Weight (one shank, without hydraulic controls)	5550 kg	12,235.64 lb
Additional Shank	340 kg	749.5 lb
Total Operating Weight* (with SU-Blade and Ripper)	48 596 kg	107,136 lb

* Total Operating Weight: Includes hydraulic controls, blade tilt cylinder, coolant, lubricants, 100% fuel, ROPS, FOPS cab, SU-Blade, Ripper, 610 mm (24 in) ES shoes, and operator.

Winches

Winch Model	PA140VS	
Weight*	1790 kg	3,947 lb
Oil Capacity	15 L	4 gal
Increased Tractor Length	557 mm	21.93 in
Winch Length	1550 mm	61 in
Winch Case Width	1160 mm	45.6 in
Drum Width	320 mm	12.6 in
Flange Diameter	457 mm	18 in
Recommended Cable size	29 mm	1.13 in
Optional Cable size	32 mm	1.25 in
Drum Capacity – Recommended Cable	84 m	276 ft
Drum Capacity – Optional Cable	59 m	193 ft
Cable Ferrule Sizes – Outside Diameter	60 mm	2.36 in
Cable Ferrule Sizes – Length	70 mm	2.75 in

- Variable speed, hydraulically driven, dual braking system, three-roller fairlead.

* Weight: Includes pump and operator controls.
With counterweight: 3705 kg (8169 lb).

Standards

- ROPS (Rollover Protective Structure) offered by Caterpillar for the machine meets ROPS criteria SAE J1040 MAY94, ISO 3471:1994.
- FOPS (Falling Object Protective Structure) meets SAE J/ISO 3449 APR98 Level II, and ISO 3449:1992 Level II.
- Operator sound exposure Leq (equivalent sound pressure level) measured according to the work cycle procedures specified in ANSI/SAE J1166 OCT 98 is 79 dB(A), for cab offered by Caterpillar, when properly installed and maintained and tested with the doors and windows closed.
- The exterior sound pressure level for the standard machine measured at a distance of 15 meters according to the test procedures specified in SAE J88 APR95, mid-gear-moving operation, is 87 dB(A).

Dimensions

All dimensions are approximate.

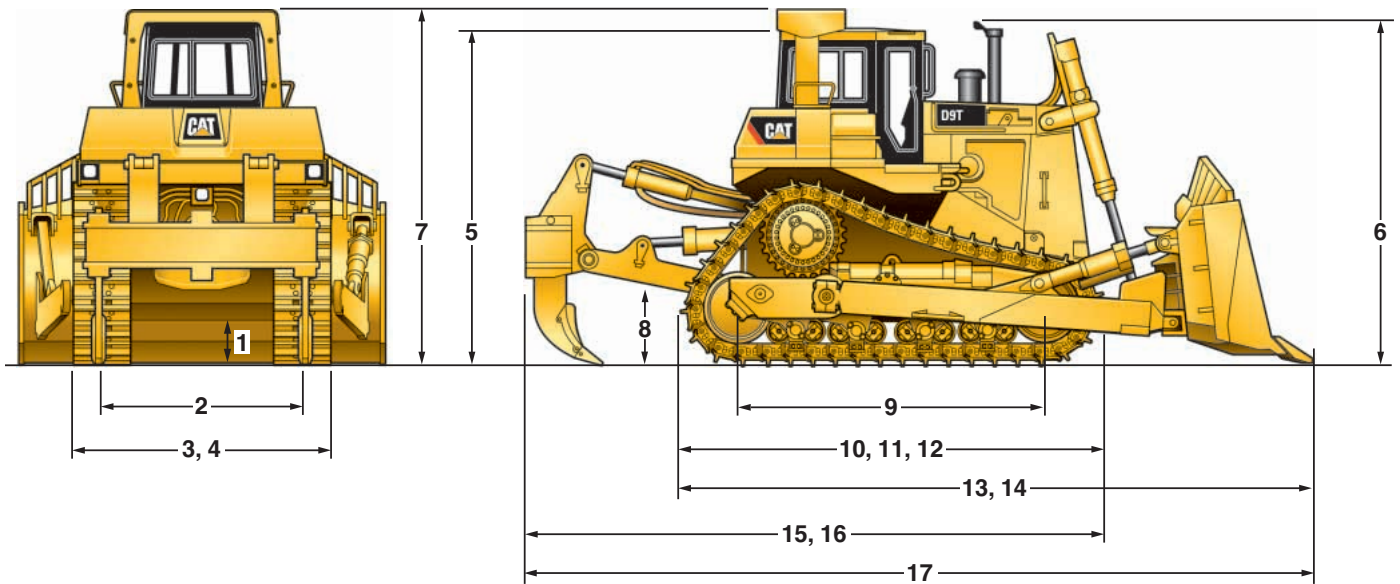

1	Ground Clearance	596 mm	23.5 in
2	Track Gauge	2.25 m	89 in
3	Width without Trunnions (Standard Shoe)	2865 mm	9.4 ft
4	Width Over Trunnions	3308 mm	10.9 ft
5	Height (FOPS Cab)	3815 mm	12.5 ft
6	Height (Top of Stack)	3980 mm	13 ft
7	Height (ROPS/Canopy)	3999 mm	13.1 ft
8	Drawbar Height (Center of Clevis)	763 mm	30 in
9	Length of Track on Ground	3474 mm	136.8 in

10	Overall Length Basic Tractor	4912 mm	16.1 ft
11	Length Basic Tractor with Drawbar	5242 mm	17.2 ft
12	Length Basic Tractor with Winch	5545 mm	18.2 ft
13	Length with SU-blade	6633 mm	21.8 ft
14	Length with U-blade	6905 mm	22.7 ft
15	Length with Single-Shank Ripper	6755 mm	22.2 ft
16	Length with Multi-Shank Ripper	6559 mm	21.5 ft
17	Overall Length (SU Blade/SS Ripper)	8476 mm	27.8 ft

Standard Equipment

Standard equipment may vary. Consult your Caterpillar dealer for details.

ELECTRICAL

- Alternator, 95-amp
- Back-up alarm
- Batteries (2), 12-volt, 200 amp-hour
- Converter, 12-volt, 10-amp
- Diagnostic connector
- Horn, forward warning
- Lighting system, Halogen
(2 forward, 2 rear)
- Starting receptacle

OPERATOR ENVIRONMENT

- Advisor-electronic monitoring system
- Armrest, adjustable
- Cab, FOPS
- Controls, electronic implement with lockout
- Decelerator pedal
- Dual-twist tiller control
- Engine speed control, electronic
- Heater and ventilation
- Hydraulic system, electronically controlled for
bulldozer and ripper control
- Mirror, rearview
- Radio-ready cab
- Seat, adjustable contour suspension
(gray fabric)
- Seat belt, retractable 76 mm (3 in)
- Wipers, intermittent

UNDERCARRIAGE

- 610 mm (24 inch) extreme service grouser
with PPR sealed and lubricated track (43 section)
- Rollers and idlers, lifetime lubricated
- Sprocket rim segments, replaceable
- Suspension-type undercarriage,
Eight-roller tubular track roller frame
- Track adjusters, hydraulic
- Track guides
- Two-piece master link

POWER TRAIN

- C18 with ACERT Technology
- 24-volt electric start
- Advanced Modular Cooling System (AMOCS)
- Aftercooler, air-to-air
- Coolant, extended life
- Directional shift management
- Ether starting aid, automatic
- Fan, suction with hydraulic demand drive
- Fuel priming pump, electric
- Muffler with rain cap
- Parking brake
- Pre-cleaner with dust ejector
- Prescreener
- Separator, water/fuel
- Thermal shields
- Torque converter
- Transmission, electronic control (ECPC), (3F/3R speeds)
- Three planet, double-reduction planetary final drives

OTHER STANDARD EQUIPMENT

- Air conditioner box, corrosive resistant
- CD ROM Parts Book
- Ecology drains: engine oil, coolant,
hydraulic oil, torque converter, fuel tank,
power train case and transmission
- Engine enclosures and hood, perforated
- Guards:
 - Bottom, hinged extreme service
 - Crankcase, hinged extreme service
 - Radiator, with towing device
 - Radiator grill doors, extreme service
- Independent steering and attachment hydraulic
pumps with Differential Steering with dual-twist
tiller control and hydraulic oil cooler
- Product Link ready
- S•O•SSM sampling ports
- Under-hood standard service lamp
- Vandalism protection (8 caplocks)

Optional Equipment

Optional equipment may vary. Consult your Caterpillar dealer for details.

ELECTRICAL

- Converter, 24-volt to 12-volt
additional 15-amp converter
- Lights, supplemental:
 - 6 Halogen
 - 10 Halogen for mining application
 - 10 Halogen for waste application
 - 11 – 6 Halogen, 5 HID for waste application
 - 11 – 6 Halogen, 5 HID for mining application

GUARDS

- Crankcase, extreme service, sealed
(part of waste handling arrangement)
- Dozer lines
- Final drive seals
- Fuel tank
- Metal hose protective sleeve
- Power train, rear upper
- Power train, rear lower
- Undercarriage

OPERATOR ENVIRONMENT

- Air conditioner
- Dual pane glass
- Powered precleaner with glass
- Glass, ultra-strength up to 40 psi
- Operators arrangement, modified
(Improves comfort for smaller operators)
- Seat, air suspension
- Seat, vinyl
- Steps, heavy-duty and Handles
- Mounting for communication radio

POWER TRAIN

- Fast fuel system
- Quick oil change system, engine and power train
- Prelube, engine

UNDERCARRIAGE

- Tracks, pair, Sealed and Lubricated:
 - 560 mm (22 in), Extreme Service
 - 685 mm (27 in), Extreme Service
 - 760 mm (30 in), Moderate Service
- Roller:
 - Carrier rollers, pin-on (one per side)

SPECIAL ARRANGEMENTS

- Mining arrangement, Stock Piling arrangement,
Waste Handling arrangement and Woodchip arrangement,
in addition to other optional attachments are available
from the factory. Contact your Dealer for availability.

BULLDOZER ATTACHMENTS

- AccuGrade GPS ready installation
(provides hydraulics, electrical, and blade mount for system)
- 9SU Blade, rock guard and wear plate
- 9SU Blade, pushplate
- 9U Blade, rock guard
- Dual tilt cylinders

RIPPERS

- Single-Shank* – Standard depth
- Single-Shank* – Deep ripping (includes pin puller)
- Multi-Shank* (includes one tooth)
- Ripper attachments:
 - Pin puller
 - Additional tooth
(for multi-shank ripper)

OTHER ATTACHMENTS

- Counterweights*:
 - Front mounted
 - Rear mounted (basic)
 - Rear mounted (additional)
- Drawbar, rigid
- Heater, diesel fuel
- Heater, engine coolant, 120- or 240-volt
- Low temperature start
(includes two additional heavy-duty batteries and
additional starting motor)
- Parts book, paper
- Striker bars, front
- Winch*

* A rear attachment and/or counterweight is recommended for improved performance and balance.

D9T Track-Type Tractor

For more complete information on Cat products, dealer services,
and industry solutions, visit us on the web at www.cat.com

© 2007 Caterpillar
All Rights Reserved
Printed in U.S.A.

Materials and specifications are subject to change without notice.
Featured machines in photos may include additional equipment.
See your Caterpillar dealer for available options.

AEHQ5591-02 (7-07)
Replaces AEHQ5591-01

CAT, CATERPILLAR, their respective logos, ACERT, ADEM, ACCUGRADE,
"Caterpillar Yellow" and the POWER EDGE trade dress, as well as corporate and product
identity used herein, are trademarks of Caterpillar and may not be used without permission.

CATERPILLAR®