

CS44 CP44

Vibratory Soil Compactors

CATERPILLAR®



Cat® C4.4 Diesel Engine with ACERT™ Technology

Gross Power	75 kW/102 hp
European Stage IIIA Compliant	

Operating Weight w/ROPS/FOPS Cab

CS44	7240 kg
CP44	7635 kg

Compaction Width

Drum Width	1676 mm
------------	---------

CS/CP44 Features

Powerful New Engine

Cat C4.4 engine with ACERT Technology provides steady, reliable, clean-burning power that meets European Stage IIIA emissions standards.

Improved Serviceability

New Cat HYDO™ Advanced 10 hydraulic oil provides a change interval increase to 3 years/3000 hours. All service performed from right side of machine. New hydraulic test port block makes oil sampling easy. Scheduled oil sampling on vibratory system is no longer required.

Excellent Gradeability and Machine Control

The exclusive Cat dual-pump propel system provides unmatched machine control with minimum drum and wheel slippage in low traction conditions.

Comfortable Operator's Station

Improved engine bay airflow reduces hot air blowback on the operator's station and excessive dust; adjustable seat, adjustable wrist rest; unrestricted visibility to the drum and rear of the machine; minimized vibrations and noise.



Contents

Overview	3
Engine	4
Propel System	4
Vibratory System	5
Smooth & Padfoot Drums	6
Operating Environment	7
Serviceability	8-9
Product Link	9
Optional Equipment	10
Customer Support	11
Training & Consulting services	11
Specifications	12-15

With a number of enhancements that improve productivity and reliability while reducing owning and operating costs, the CS44 and CP44 Vibratory Soil Compactors are the latest evolution of a class-leading design. Throw in the durable and field-proven powertrain and vibratory system, along with unmatched customer service and support, and it is easier than ever to see why you can Count on Cat.

Ready to Go

Robust, versatile and highly mobile, the CS44 and CP44 can do it all.

With all the choices available, what makes the Cat CS44 and CP44 the smart and easy decision for your soil compactor purchase?

Easy to Use

Controls are where you expect them to be. Dials and indicators tell you what you need to know. The comfortable operating station enables the operator to stay alert, safe and productive.

High Productivity

The Cat dual-pump propel system provides excellent mobility and gradeability. The exclusive Cat pod-style vibratory system provides reliable compactive effort with lower system noise than competitive machines.

High Versatility

Useful options, like the padfoot shell kit and leveling blade, enhance the versatility and use of the CS44 and CP44.

Increased Reliability and Durability

A powerful new engine with an improved, more robust design, coupled with a bigger, more efficient cooling package, gives the CS44 and CP44 an edge over competitive machines.

Lower Owning and Operating Costs

The CS44 and CP44 feature enhanced serviceability, decreasing machine maintenance time and lowering cost of ownership. The longest available service intervals for vibratory system and hydraulic oil service, parts commonality with other Cat equipment and right-side service design also contribute to lowered costs. Compare our owning and operating costs with the competition and you will see why the CS44 and CP44 are the easy choice.

A Name You Know

You already trust Caterpillar for your earthmoving equipment—why would you trust anyone else for your compaction equipment? Your Cat Dealer provides unmatched service on your entire fleet, reducing maintenance and service costs. One single source who understands the needs of your business. And, the Caterpillar brand means that when it is time to buy new equipment, you will receive the maximum resale value on the equipment you are replacing.



Engine and Propel System

Advanced engine and hydraulics are durable, reliable and productive.

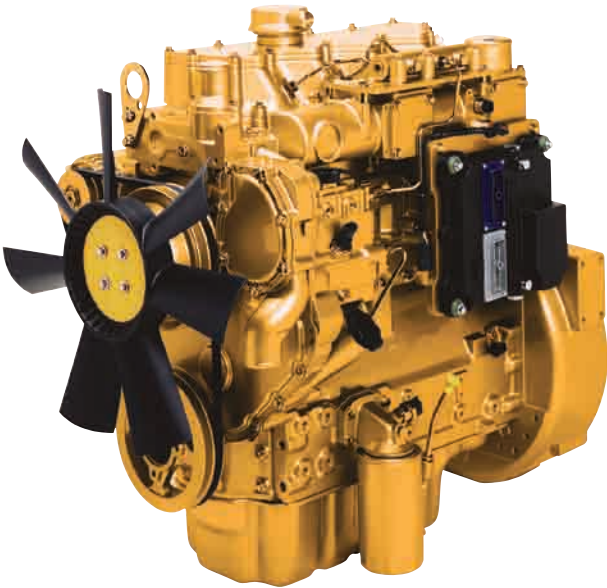

A smooth, robust and clean-burning engine combined with state-of-the-art hydraulic components and the exclusive Cat dual-pump design make the CS44 and CP44 agile, quick and dependable.

Powerful C4.4 Engine with ACERT™ Technology

This high-tech four cylinder engine provides outstanding durability, performance, reliability and operating economy while producing less emissions. ACERT Technology combines proven systems with innovative new technologies to precisely shape the combustion process, providing more complete combustion of fuel and lower emissions. The C4.4 engine meets European EU Stage IIIA emissions standards.

More Robust Block and Components

The C4.4 has been built with a thicker engine block and more robust components, improving durability and reliability while helping to keep noise levels low. The robust design also contributes to improved cold-weather starting performance.

Low-mounted Oil Pump, Large Oil Cooler

The positioning of the oil pump provides quick start-up lubrication, ensuring less engine wear and a longer engine life. The cooling package has been increased in size by 25%, reducing oil deterioration and varnishing of internal components as well as operating temperatures. Engine oil change interval is every 500 hours.

Dual-Pump Propel System

The dual-pump propel system, unique to Cat compactors, has dedicated pumps to drive the heavy-duty, high-torque rear wheel and drum motors independently. Should the drum or wheels begin to spin, the non-spinning motor still receives hydraulic flow, allowing continuous tractive effort especially useful in loose underfoot conditions.

- 1 Dual Propel Pumps
- 2 Cat C4.4 Engine Motor
- 3 Limited Slip Differential
- 4 Rear Wheel Drive
- 5 Drum Drive Motor

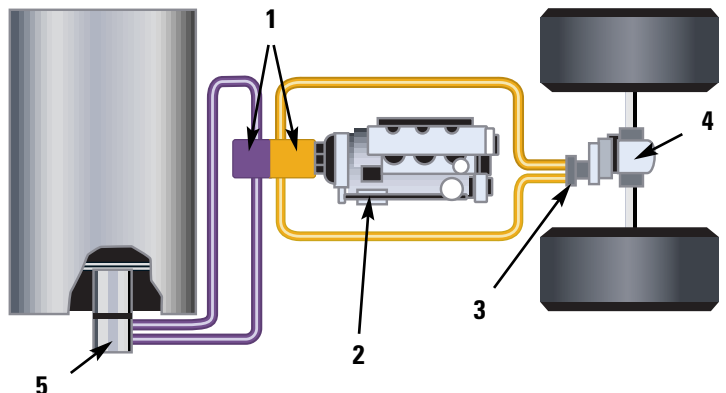

Too steep? Not likely.

Power and traction get you where you need to go.

The Cat Dual-Pump Propel System, coupled with a limited slip differential on the rear axle, provides smooth balanced power to the wheels and drum, allowing the CS44 and CP44 to climb the steepest embankments and trench ramps.

Proven Vibratory System

Superior performance, minimum maintenance.

Caterpillar's pod-style vibratory system delivers superior compactive force, industry-leading serviceability and smoother, more quiet operation.

Pod-style Weight Housing is a Proven Design

Assembled and sealed at the factory to ensure cleanliness, longer bearing life and easier field exchange or service.

Dual Amplitude Increases Versatility

Works efficiently in a wider range of applications. High or low amplitude is selected from the operator's station.

High Compaction Force with Versatile Options

31.9 Hz vibratory frequency brings high-production compaction force to bear. Optional variable frequency control allows operator to adjust frequency to match varying job conditions.

Minimal Maintenance

3 year/3,000 hour vibratory bearing change is unmatched by competitive models. Scheduled oil sampling is no longer required on proven design.

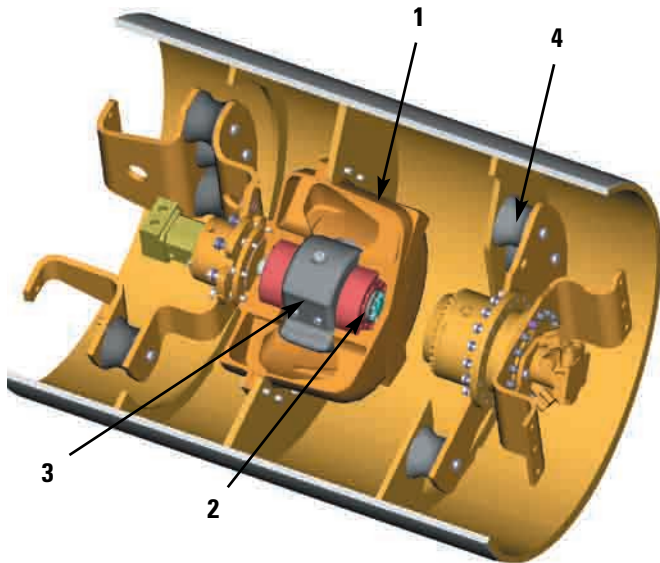

- 1 Pod-style Weight Housing
- 2 Exclusive Eccentric Weights
- 3 Heavy-duty Bearings
- 4 Isolation Mounts

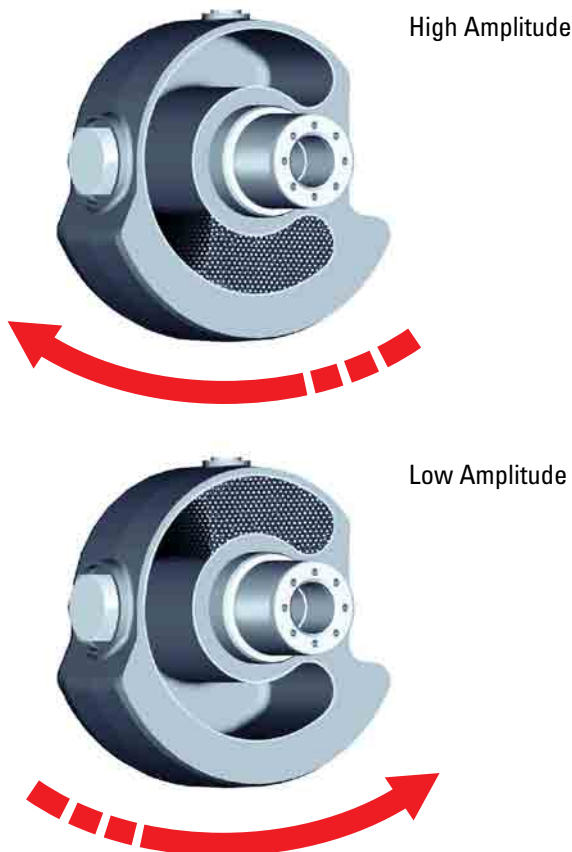

Reliability Through Innovation

Exclusive Eccentric Weight design ensures precise performance.

Simple, Certain Control

The proprietary eccentric weights, activated from a thumb switch on the propel lever, feature a design that utilizes repositioning steel shot to change amplitude. This design assures smooth, low-noise, positive activation as the round shot fluidly shifts position.

High Reliability

Unlike the clunky, steel plate designs of competitive models, the steel shot cannot jam, and repositioning does not create metal fragments that can contaminate the bearing lubrication system.

Smooth Drum CS44

Excellent performance while compacting granular materials.



Durable and Versatile

The heavy-duty smooth drum provides excellent performance for use on granular materials. The smooth drum can be fitted with an optional removable padfoot shell kit to enhance machine capabilities on semi-cohesive and cohesive soils.

Scraper Design

A steel scraper on the front of the drum is adjustable to keep it in consistent contact with the drum surface, improving performance.

Scraper Options

Optional scrapers are available, including a steel scraper for the rear of the drum and polyethylene scrapers that provide enhanced drum contact.

Padfoot CP44

High ground contact pressure.

High-production Design

The padfoot drum has 108 pads welded in a chevron arrangement. Padfoot drums offer superior performance when compacting cohesive and semi-cohesive materials.

Round Pad Design

Round pad is 90 mm high with a pad face surface area of 63.8 cm² for high ground contact pressure and maximum compaction. Tapered, self-cleaning design allows pads to walk out of the lift without fluffing or “kicking up” the soil around the pads.

Drum Scrapers

Wide, individually adjustable and replaceable scrapers mounted on the front and rear of the drum reduce excessive material build-up between the pads.

Padfoot Drum shown with optional Leveling Blade attachment.





Operating Environment

Features and options to maximise operator comfort and productivity.

Available with a standard ROPS/FOPS Canopy or an optional ROPS/FOPS Cab, the CS44 and CP44 provide excellent operator comfort, which facilitates high productivity. The operator's platform is isolated from the frame with heavy duty isolation mounts, which reduce vibration to the operator.

Optional ROPS/FOPS Cab

The ROPS/FOPS Cab is spacious and comfortable, with large windows and exceptional visibility. Excellent ergonomics and low sound levels keep the operator alert and in control. Standard cab features include:

- A comfortable, adjustable cloth seat
- Internal rear view mirror and two exterior rear view mirrors
- Two front-facing and two rear-facing working lights
- A cab lift cylinder for greater access to the hydraulic pump package
- Front and rear windshield wipers
- Slide-open side windows
- Climate control with air conditioning, a heater and defroster
- Pre-wired for the addition of a radio set (radio not included)
- 12-volt outlet for personal communication devices
- Lockable personal storage bin and cupholder/lunchbox storage



Operator's Station

A tilting steering console provides maximum comfort and easy egress. All controls, levers, switches and gauges are positioned for easy use. The comfortable and durable seat provides adjustment for forward and backward positioning, seat height and suspension stiffness. The seat has flip-up arm rests and a 76 mm wide retractable seat belt. An adjustable wrist rest mounted near the propel lever reduces operator fatigue from extended operation. A floor mat reduces vibrations. An optional rotating seat provides 20 degrees of pivot adjustment.

Industry Leading Serviceability

Cat machines are designed to keep owning and operating costs low.

Cat customers know that much of the value of a Cat machine is realized away from the job site. Cat machines are designed for easy maintenance and long service intervals, maximizing uptime and minimizing costs.

Visual Indicators

Allow easy and fast check of engine coolant, hydraulic oil tank level, and air filter restriction.

Operator's Station Tilts Forward

Allows convenient access to hydraulic pumps.

Rear Mounted Cooling System

Provides easy access for cleaning. Hydraulic oil cooler tilts rearward for additional access to radiator.

Maintenance-free Articulation Hitch

Articulation hitch has sealed-for-life bearings, eliminating need for greasing or maintenance.

500 Hour Engine Oil Service Interval

3 Year/3,000 Hour Vibratory Bearing Lube Service Interval

Extended service interval reduces maintenance costs and maximizes uptime. Scheduled oil sampling of vibratory system no longer required.

3 Year/3,000 Hour Hydraulic Oil Service Interval

The CS/CP44 comes with a standard factory fill of Cat HYDO™ Advanced 10 hydraulic oil, which extends service intervals, reduces maintenance costs and maximizes uptime. With standard oils, the service interval is 2 years/2,000 hours. Cat HYDO Advanced 10 extends the interval to 3 years/3,000 hours.

S•O•SSM Ports

Allow for simple fluid collection of engine oil, engine coolant and hydraulic oil.

Quick Connect Hydraulic Test Ports

Simplify system diagnostics.

Parts Commonality

The CS44 and CP44 share common parts with other Cat soil compactors and machines, minimizing the number of wear and service parts owners will need on hand.

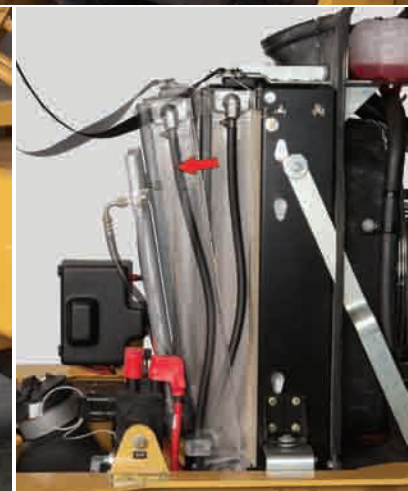

Ground level access, right-side-of-machine service, and visual indicators are just a few of the features that make Cat machines easier and less expensive to service than the competition. The CS44 and CP44 also feature a maintenance-free articulation hitch and a tilting oil cooler for greater service access.



- | | | |
|------------------------------------|--|--|
| 1 Coolant level indicator | 7 Engine oil fill, dipstick, filter | 11 Maintenance-free articulation hitch |
| 2 Air restriction indicator | 8 Hydraulic test port block | 12 Fuel/Water separator filter and indicator |
| 3 Tilting oil cooler | 9 Hydraulic oil level indicator | 13 Low Maintenance Vibratory System – 3 years/3,000 hours |
| 4 Jump start connector | 10 Platform lift cylinder | |
| 5 Fuel fill | | |
| 6 Ecology drain | | |

Secure Hose Routing

Polyethylene hose mounting looms reduce rubbing, keep the systems organized and increase service life.

Robust Electrical System Design

Nylon-braided wrap and all-weather connectors ensure system integrity. Electrical wiring is color-coded, numbered and labeled with component identifiers to simplify troubleshooting. New breaker block design provides easier access to breakers.

Maintenance-free Cat Batteries

Provide 750 cold-cranking amps. Maintenance-free Articulation Hitch Articulation hitch has sealed-for-life bearings, eliminating need for greasing or maintenance.

Ecology Drains

Provide a method to drain fluids that is more environmentally safe. They are included on the radiator, engine oil pan, hydraulic tank and fuel tank.

Simplified Fleet Tracking

Product Link option ensures maximum uptime and minimizes maintenance.

Machines are wire-ready to accept Product Link. Optional Product Link streamlines diagnostic efforts, downtime, and maintenance scheduling and costs by providing communication flow of vital machine data and location information between the dealer and the customer. Product Link provides updates on service meter hours, machine condition and machine location.

Two-way Wireless Data Flow

Provides communication between on-board machine systems and the Cat Dealer and owner.

Product Watch

Optional Product Watch service monitors your fleet for unauthorized machine usage. Product Watch notifies owner via email or pager if a machine operates outside of a configurable set of parameters.



Expand Your Productivity

Optional equipment adds to the versatility of your machine.

Padfoot Shell Kit

Available for the CS44, the padfoot shell kit extends the application range of smooth drums to include semi-cohesive and cohesive soils. Padfoot shell comes in two halves that can be easily installed with an appropriate lifting device in about an hour. Kit also comes with a dual purpose bumper that provides storage for scrapers. Padfoot scrapers feature a new design that provides increased removal of materials from the drum face. The shell features 98 pads with a pad height of 90 mm.

Leveling Blade

Available on the CP44 and CS44 models equipped with the shell kit. The leveling blade is controlled with a foot pedal, allowing operators to keep their hands on the steering wheel and propel lever during blade operation. The leveling blade can perform multiple functions, including material knockdown, site leveling, trench backfilling and light dozing. The blade features two-piece, reversible and replaceable cutting edges that increase service life and reduce replacement costs.

ROPS/FOPS Cab

In markets where the cab is not standard equipment, the cab is available as an option. The cab improves productivity by increasing operator comfort.

Variable Vibration Frequency

Allows operator to vary the drum vibration frequency to match drum performance to site conditions.

VPM Gauge

Mounted on the console, this gauge displays the actual vibratory system frequency.

Volkel Ready Option

CS44 models can be equipped with the Volkel Analog Compaction Display (ACD), a simple compaction measurement gauge, by ordering the Volkel Ready Option, which provides a pre-installed accelerometer/processor on the drum and an electrical harness routed to the operator's console. The Volkel ACD is purchased separately from Volkel and installed on the operator's console by your dealer.

Operator Comfort Options

- Sun Visor
- Cab Internal Rear View Mirrors
- Roll-down Sun Screen
- Rotating Seat
- Rotating Beacon



Smooth Drum Performance Options

- Polyurethane Drum Scrapers
- Steel Rear Drum Scraper

Maintenance Options

- Operator Platform Lift Cylinder
- Bio-Oil Ready Option

Customer Support

Unmatched support makes the difference!

Your Cat dealer is ready to assist you with your purchase decision and everything after.

- Make comparisons of machines with estimates of component life, preventative maintenance and cost of production.
- Financing packages are flexible to meet your needs.
- Your Cat dealer can evaluate the cost to repair, rebuild and replace your machine, helping you can make the right choice.
- For more information on Cat products, dealer services and industry solutions, visit us at www.cat.com.



Training and Consulting Services

Get the most out of your machine purchase and employees.

Cat Global Paving is proud to offer our industry-leading application and machine maintenance training for the paving industry. To learn more, speak with your local Cat Dealer.

Classes Lower Maintenance Costs, Increase Uptime

Classes focus on maintenance issues unique to machines used in the paving industry. Students learn the machine systems, preventative maintenance and troubleshooting skills.

Improve Production and Quality; Maximize Profits

Classes provide expert industry and technical knowledge, plus Best Practices application knowledge, to streamline your work force and hone their skills.

CS/CP44 Vibratory Soil Compactor Specifications

Engine

Model: Cat C4.4 four cylinder liquid cooled diesel engine with ACERT rated at 2200 rpm.

Rated Power

Net: ISO 9249	70.3 kW / 95.6 hp
Gross power ISO14396	75 kW / 102 hp
Bore	105 mm
Stroke	127 mm
Displacement	4.4 L

- All engine horsepower (hp) are metric including front page.
- Ratings of Caterpillar machine engines are based on standard air conditions of 25°C and 100 kPa dry barometer.
- Power is based on using API gravity of 35 at 15°C, fuel having a LHV of 42 780 kJ/kg used at 30°C [ref. a fuel density of 838.9 g/L].
- Net power shown is the power available at the flywheel when the engine is equipped with alternator, air cleaner, muffler and fan.
- Net Power ratings are tested at the reference conditions for the specified standard.
- No derating required up to 3000 m altitude. Auto derate protects hydraulic and transmission systems.
- The Cat C4.4 engine meets Stage IIIA off-highway emission regulations.

Transmission

Two variable-displacement piston pumps supply pressurized flow to two dual-displacement piston motors. One pump and motor drives the drum propel system while the other pump and motor drives the rear wheels. The dual-pump system ensures equal flow to the drive motors regardless of the operating conditions. In case the drum or wheels lose traction, the other motor can still build additional pressure to provide added torque.

The drive motors have two swashplate positions allowing operation at either maximum torque for compaction and gradeability or greater speed for moving around the job site. A rocker switch at the operator's console triggers an electric over hydraulic control to change speed ranges.

Speeds

Work	0 - 5.5 km/h
Travel	0 - 12.3 km/h

Final Drives and Axle

Final drive is hydrostatic with planetary gear reducer to the drum and hydrostatic with differential and planetary gear reduction to each wheel.

Axle

Heavy-duty fixed rear axle with a limited slip differential for smooth and quiet torque transfer.

Axle width	1.27 m
Tyres	
CS44	14.9" x 24" 6-ply flotation
CP44	14.9" x 24" 8-ply flotation

Steering

A priority-demand hydraulic power-assist steering system provides smooth low-effort steering. The steering system has priority over other hydraulic functions.

Minimum turning radius

Inside drum edge	3080 mm
Outside drum edge	4750 mm
Steering angle (each direction)	+/- 37°
Oscillation angle (each direction)	+/- 15°

Hydraulic system

Two 64 mm bore, double-acting cylinders powered by a gear pump

Brakes

Service Brake Feature

Closed-loop hydrostatic drive system provides dynamic braking during operation.

Secondary and Parking Brake Features

Spring-applied/hydraulically released multiple disc-type brake mounted on the drum drive gear reducer and rear axle. Secondary brakes are activated by: a button on the operator's console; loss of hydraulic pressure in the brake circuit; or when the engine is shut down. A brake interlock system helps prevent driving through the secondary brake.

Braking system meets EN 500-4.

CS/CP44 Vibratory Soil Compactor Specifications

Instrumentation

The Electronic Control Module (ECM) constantly monitors condition of the engine, and alerts the operator of problems with three levels of warning. Warning system includes: Action Alarm and Lamp, Low Engine Oil Pressure, High Engine Coolant Temperature, High Hydraulic Oil Temperature, Low Charge Pressure, Starting Aid and High Combustion Air Temperature. Instrumentation also includes an Alternator Malfunction Light, Check Engine/Electrical Fault, Service Hour Meter and Fuel Gauge.

Drum and Vibratory System

Dimensions	CS44	CP44
Drum width	1676 mm	1676 mm
Drum shell thickness	25 mm	25 mm
Drum diameter	1221 mm	1225 mm
Number of pads	—	108
Pad height	—	90 mm
Pad face area	—	63.8 cm ²
Number of chevrons	—	12
Eccentric weight drive	Hydrostatic	Hydrostatic

Weights at the Drum

With ROPS/FOPS canopy	3410 kg	3760 kg
With ROPS/FOPS Cab and AC	3510 kg	3680 kg
Static linear load	20.3 kg/cm	—

Vibratory System

Standard	31.9 Hz	31.9 Hz
Optional	23.3 - 31.9 Hz	23.3 - 31.9 Hz
Nominal amplitude		
High	1.67 mm	1.59 mm
Low	0.84 mm	0.80 mm
Centrifugal force @ 31.9 Hz		
Maximum	134 kN	134 kN
Minimum	67 kN	67 kN

Frame

Fabricated from heavy gauge steel plate and rolled sections and joined to the drum yoke at the articulation pivot. Articulation area is structurally reinforced and joined by hardened steel pins. One vertical pin provides a steering angle of $\pm 37^\circ$ and a horizontal pin allows frame oscillation of $\pm 15^\circ$. The articulation lock prevents machine articulation when placed in the locked position. Sealed-for-life hitch bearings require no maintenance. Frame also includes tie-down points for transport.

Electric System

The 24-volt electrical system consists of two maintenance-free Cat batteries, electrical wiring is color-coded, numbered, wrapped in vinyl-coated nylon braid and labeled with component identifiers. The starting system provides 750 cold cranking amps (cca). The system includes a 75-amp alternator. A new breaker block provides easy access to breakers.

Service Refill Capacities

	liter
Fuel tank	180
Cooling system	20.5
Engine oil w/filter	8.5
Eccentric weight housings	6
Axles & final drives	10.5
Hydraulic tank	80

CS/CP44 Vibratory Soil Compactor Specifications

Dimensions

All dimensions are approximate.

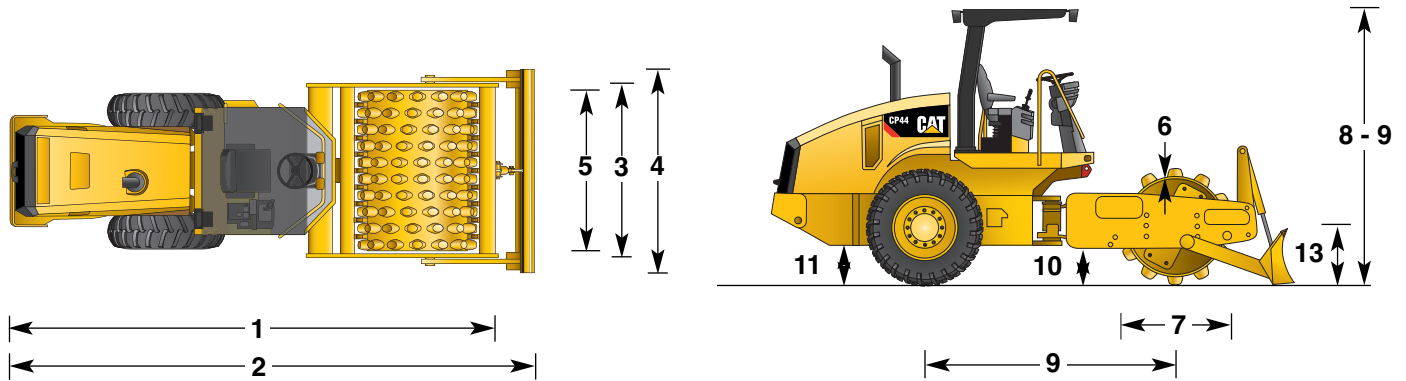

	CS44 mm	CP44 mm
1 Overall length	5080	5080
2 Overall length w/optional leveling blade	5440	5440
3 Overall width	1800	1800
4 Overall width w/optional leveling blade	2120	2120
5 Drum width	1676	1676
6 Drum shell thickness	25	25
7 Drum diameter	1221	1225
8 Overall height at ROPS/FOPS canopy	2930	2930
9 Overall height at ROPS/FOPS cab	2970	2970
10 Wheelbase	2600	2600
11 Curb clearance	380	380
12 Ground clearance	411	411
13 Optional leveling blade height	574	574
Inside turning radius	3080	3080
Outside turning radius	4750	4750

Maximum machine weight includes all attachments, full fluids and an 80 kg operator.

Standard operating weights include lubricants, coolant, 80 kg operator, half full fuel tank, full hydraulic system and half full water tank.

CS/CP44 Vibratory Soil Compactor Specifications

CS44 and CP44 Specifications

Operating Weights	CS44	CP44
With ROPS/FOPS cab, AC	7240 kg	7635 kg
equipped with padfoot shell kit	8230 kg	—
equipped with padfoot shell kit and blade	8710 kg	—
equipped with blade	—	8045 kg
With ROPS/FOPS canopy	6900 kg	7295 kg
equipped with padfoot shell kit	7890 kg	—
equipped with padfoot shell kit and blade	8370 kg	—
equipped with blade	—	7705 kg
Weight at Drum		
With ROPS/FOPS cab, AC	3510 kg	3860 kg
equipped with padfoot shell kit	4500 kg	—
equipped with padfoot shell kit and blade	5160 kg	—
equipped with blade	—	4410 kg
With ROPS/FOPS canopy	3410 kg	3760 kg
equipped with padfoot shell kit	4400 kg	—
equipped with padfoot shell kit and blade	5060 kg	—
equipped with blade	—	4310 kg
Static Linear load (at drum)		
With ROPS/FOPS cab, AC	20.9 kg/cm	—
With ROPS/FOPS canopy	20.3 kg/cm	—
Power Train		
Engine	C4.4 ACERT	C4.4 ACERT
Gross power	75 kW/102 Hp	75 kW/102 Hp
Maximum speeds		
High range	12.3 km/h	12.3 km/h
Low range	5.5 km/h	5.5 km/h
Axle (differential)	Limited Slip	Limited Slip
Tyre size	14.9" x 24" 6-ply	14.9" x 24" 8-ply
Miscellaneous		
Electrical system	24 VDC	24 VDC
Articulation angle	± 37°	± 37°
Oscillation angle	± 15°	± 15°
Fuel capacity	180 liters	180 liters

CS/CP44 Vibratory Soil Compactor

For more complete information on Cat products, dealer services, and industry solutions, visit us on the web at www.cat.com

HEHG4318 (11/2009) hr

Materials and specifications are subject to change without notice. Featured machines in photos may include additional equipment. See your Caterpillar dealer for available options.

© 2009 Caterpillar – All rights reserved

Cat, Caterpillar, their respective logos, “Caterpillar Yellow” and the POWER EDGE trade dress as well as corporate and product identity used herein, are trademarks of Caterpillar and may not be used without permission.

CATERPILLAR[®]