



600 kVA, 480 kW

50 Hz, Prime

BENEFITS & FEATURES

CAT® DIESEL ENGINES

The four-cycle Cat diesel engine combines consistent performance with excellent fuel economy and transient response that meets ISO 8528-5. The engines feature a reliable, rugged, and durable design that has been field proven in thousands of applications worldwide in emergency standby installations.

CAT NOISE ENCLOSURE

The Genset is approved as per CPCB India Regulations. The Noise Enclosures are designed for easy access of all engine parts, and lube oil fumes disposal. The enclosures are made of Non-igniting, self-extinguishing mineral wool 100 mm thick with resin bonded, used for noise and thermal insulation

COOLING SYSTEM

The cooling system has been designed and tested to ensure proper generator set cooling, and includes the radiator, fan, belts, and all guarding installed as standard. Contact your Cat dealer for specific ambient and altitude capabilities.

GENERATORS

The generators used on Cat packages have been designed and tested to work with the Cat engine. The generators are built with robust Class H insulation and provide industry-leading motor starting capability and altitude capabilities.

CONTROL PANELS

The TCP 1000 is a compact Auto Mains (Utility) Failure Control Module that has been developed to provide an outstanding range of features. Monitoring engine speed, oil pressure, coolant temperature, frequency, voltage, current & power, the modules will give comprehensive engine and alternator protection.

SPECIFICATIONS

ENGINE SPECIFICATIONS

Engine Model	Cat® C18 ACERT In-line 6, 4-cycle diesel
Bore x Stroke	145mm x 183mm (5.7in x 7.2in)
Displacement	18.1 L (1106 in ³)
Compression Ratio	14.5:1
Aspiration	Air-to-Air Aftercooled
Fuel Injection System	MEUI™
Governor	Electronic ADEM™ A4
Emission Certifications	India CPCB/ MoEF Standards

GENERATOR SET SPECIFICATIONS

Alternator Design	Brushless Single Bearing, 4 Pole
Stator	2/3 Pitch
No. of Leads	06
Available Voltage Options	415V
Frequency	50Hz
Alternator Voltage	24V
Alternator Insulation & IP	Class H; IP23
Standard Temperature Rise	125°C
Available Excitation Options	Self-Excited.
Voltage Regulation	±1%
Voltage Regulator	R150M

STANDARD & OPTIONAL EQUIPMENT

Air inlet system	Single element canister-type air cleaner Service indicator Heavy Duty Air Cleaner (Optional)
Control panels	TCP 1000 Controller EMCP4.2 control panel(Optional). Emergency stop push button
Cooling system	Radiator fan and belt drive Fan and belt guard Coolant drain line with valve Coolant level sensor Cat extended life coolant
Exhaust system	Dry exhaust manifold Flanged faced outlets Exhaust mufflers Stainless steel exhaust flex fittings Flanges
Fuel system	Primary and secondary fuel filters Fuel priming pump Flexible fuel lines Engine fuel transfer pump Integrated fuel cooler Enclosure integrated fuel tank
Generators and generator attachments	Self excited Class H insulation Class H temperature rise Random Wound R150M voltage regulator Power terminal strip connections IP 23 protection
Governing system	Cat Electronic Governor (ADEM™ A4).
Lube System	Lubricating oil and filter Oil drain line with valves Fumes disposal Gear type lube oil pump Lube oil level indicator (dipstick)
Mounting	Anti-vibration mounts
Starting/charging system	24 volt starting motor Batteries with rack and cables 45 amp charging alternator
General	SAE standard rotation Flywheel – SAE No.14 Flywheel housing – SAE No. 0.5 Paint – Caterpillar Yellow (except rails and radiators gloss black)

Prime: 50Hz; 415V



Engine Model	Cat® C18 ACERT In-line 6, 4-cycle diesel
Bore x Stroke	145mm x 183mm (5.7in x 7.2in)
Displacement	18.1 L (1106 in³)
Compression Ratio	14.5:1
Aspiration	Air-to-Air Aftercooled
Fuel Injection System	MEUI™
Governor	Electronic ADEM™ A4

Model	Prime	Emission Strategy
C18	600 kVA, 480 ekW	India CPCB/ MoEF Standards

PACKAGE PERFORMANCE

Performance	Prime
Frequency	50 Hz
Genset Power Rating	600 kVA
Gen set power rating with fan @ 0.8 power factor	480 ekW
Fuelling strategy	India CPCB/ MoEF Standards
Performance Number	EM0553
Fuel Consumption	
100% load with fan	123.0 L/hr, 32.5 gal/hr
75% load with fan	97.3 L/hr, 25.7 gal/hr
50% load with fan	67.7 L/hr, 17.8 gal/hr
25% load with fan	38.3 L/hr, 10.1 gal/hr
Cooling System ¹	
Radiator air flow restriction (system)	0.12 kPa, 0.48 in. Water
Radiator air flow	660 m³/min, 23308 cfm
Engine coolant capacity	20.8 L, 5.4 gal
Radiator coolant capacity	20 L, 5.2 gal
Engine coolant capacity with Radiator/Exp Tank	48.8 L, 12.28gal
Inlet Air	
Combustion air inlet flow rate	37.8 m³/min, 1334.8 cfm
Max. Allowable Combustion Air Inlet Temp	48 °C, 118 °F
Exhaust System	
Exhaust stack gas temperature	511 °C, 951.8 °F
Exhaust gas flow rate	105.3 m³/min, 3718.6 cfm
Exhaust system backpressure (maximum allowable)	10.0 kPa, 40.0 in. water
Heat Rejection	
Heat rejection to jacket water	151 kW, 8587 Btu/min
Heat rejection to exhaust (total)	483 kW, 27468 Btu/min
Heat rejection to atmosphere from engine	75 kW, 4265 Btu/min
Heat rejection to atmosphere from generator	26 kW, 1501 Btu/min
Lube System	
Sump Refill with Filter	62.0 L, 16.3 gal

Alternator ²	
Voltages	415V
Current	834.7A
Motor Starting Capability @ 25% Voltage Dip	800 skVA
Frame Size	LSAP47E
Excitation	Self-excited
Temperature Rise	125°C

DEFINITIONS AND CONDITIONS

¹For ambient and altitude capabilities consult your Cat dealer. Air flow restriction (system) is added to the existing restriction from the factory.

²Generator temperature rise is based on a 40°C (104°F) ambient.

APPLICABLE CODES AND STANDARDS: ISO 3046, ISO 8528, IEC60034-1, IS4722

Prime: Output available with varying load for an unlimited time. Prime power in accordance with ISO 8528. 10% overload power in accordance with ISO 3046.

Ratings: Ratings are based on SAE J1349 standard conditions. These ratings also apply at ISO 3046 standard conditions.

Fuel Rates: Fuel Consumption reported in accordance with ISO 3046-1.

Additional ratings may be available for specific customer requirements, contact your Cat representative for details.

WEIGHTS & DIMENSIONS*

Genset Model	Dim "A" mm (in)	Dim "B" mm (in)	Dim "C" mm (in)	Generator Set Weight kg (lb)
600 kVA, 480 ekW	5,450 (215)	2,000 (79)	2,200 (87)	5,990 (13,206)

* Note: For reference only – do not use for installation design. Please contact your local dealer for exact weights and dimensions

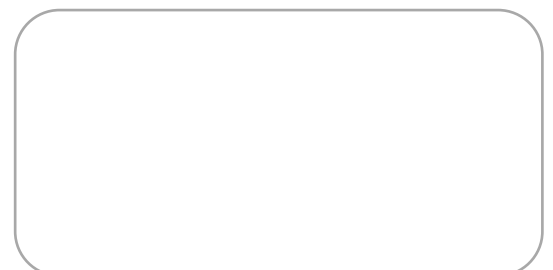
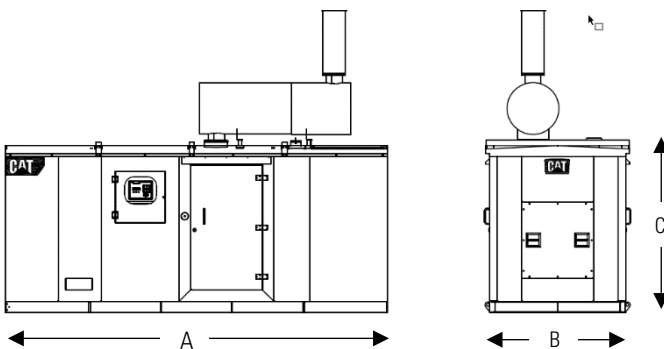

BUILT FOR IT.™

www.Cat.com/electricpower

©2018 Caterpillar All rights reserved. Materials and specifications are subject to change without notice. CAT, CATERPILLAR, their respective logos, ADEM, S•O•S, BUILT FOR IT, "Caterpillar Yellow", the "Power Edge" trade dress as well as corporate and product identity used herein, are trademarks of Caterpillar and may not be used without permission.